

E43 POWERHEAD & AUGER PARTS

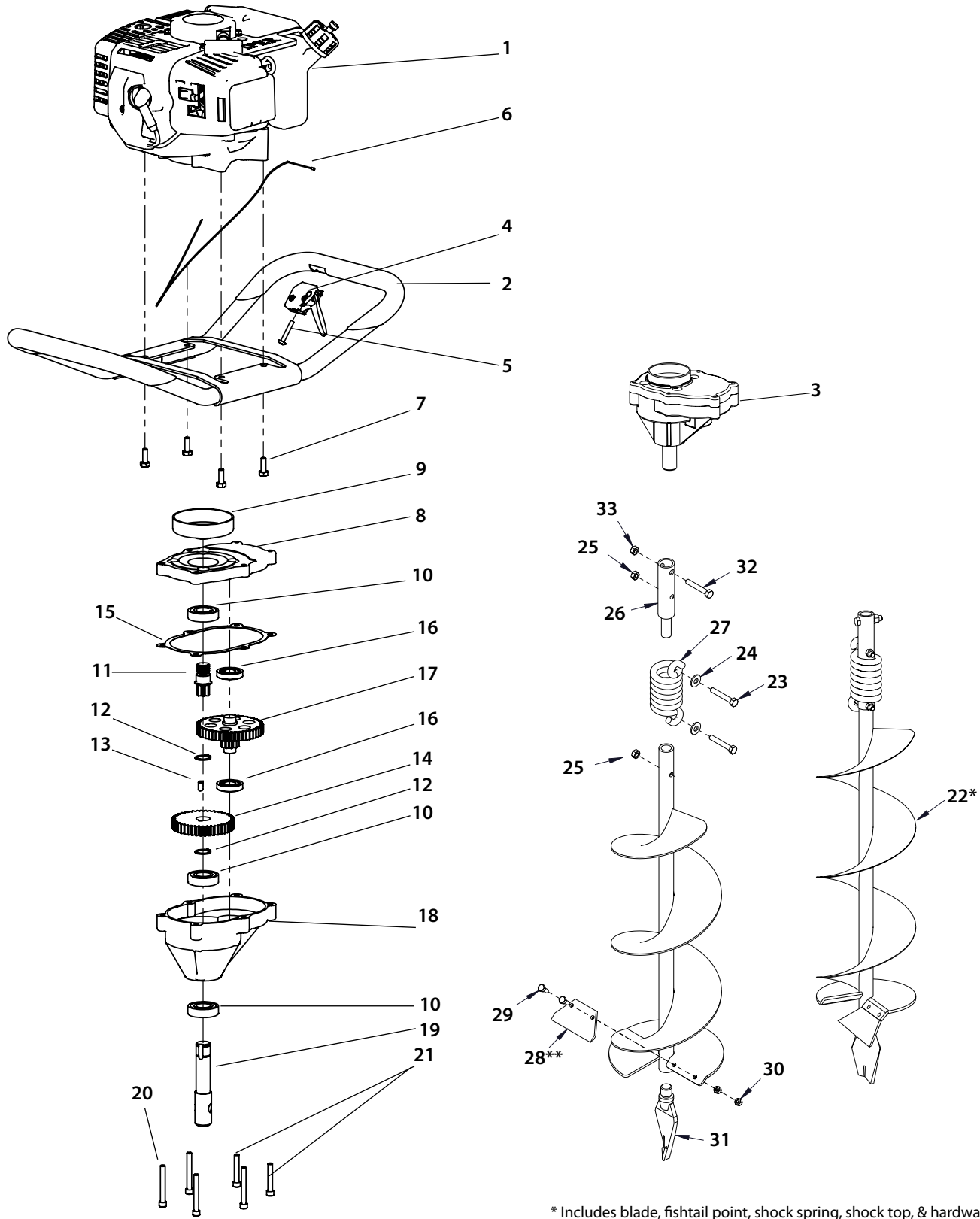

* Includes blade, fishtail point, shock spring, shock top, & hardware.

** Includes mounting hardware.

E43 POWERHEAD PARTS LIST

KEY NO.	PART NO.	DESCRIPTION	QTY.
1	E43CCV	GAS ENGINE, 43CC	1
2	4828	HANDLEBAR, FOAMED	1
3	3004119	TRANSMISSION COMPLETE	1
4	4809	TRIGGER ASSEMBLY	1
5	4814	BOLT 10-24 X 1-1/4 PHILLIPS TRUSS HD	1
6	4811	THROTTLE CABLE	1
7	8930B	BOLT 1/4-20 X 3/4 HH GR5 BLK	4
8	3004111	GEAR CASE TOP	1
9	3004100	CLUTCH DRUM	1
10	8922	BALL BEARING R12 DOUBLE LIP	3
11	9814	GEAR 7T PINION THREADED, 5/8" THREAD	1
12	8924	SNAP RING	2
13	8915	DOWEL PIN STEEL 1/4" X 1/2"	1
14	8912	GEAR 44T 3/4" HOLE	1
15	8919	GASKET	1
16	8923	BALL BEARING R10	2
17	9214	GEAR 10T/48T ONE-PIECE CLUSTER	1
18	8939	GEAR CASE BOTTOM	1
19	8913	SHAFT OUTPUT 7/8"	1
20	8929	BOLT 1/4-20 X 1-1/2 SHCS	2
21	8931F	BOLT 1/4-20 X 2 SHCS F-T	4
22*	EA2F	EARTH AUGER 2", COMPLETE	1
	EA3F	EARTH AUGER 3", COMPLETE	1
	EA4F	EARTH AUGER 4", COMPLETE	1
	EA6F	EARTH AUGER 6", COMPLETE	1
	EA8F	EARTH AUGER 8", COMPLETE	1
	EA10F	EARTH AUGER 10", COMPLETE	1

AUGER PARTS & ACCESSORIES LIST

KEY NO.	PART NO.	DESCRIPTION	QTY.
23	1423	BOLT 5/16-18 X 2 HHCS GR5	2
24	WF516	WASHER, FLAT 5/16" STANDARD	2
25	60G56	NUT 5/16-18 BI-WAY LOCK	2
26	53684	SHOCK TOP 1-PC	1
27	8980	SHOCK SPRING	1
28**	EB4	EARTH BLADE, 4"	1
	EB6	EARTH BLADE, 6"	1
	EB8	EARTH BLADE, 8"	1
	EB10	EARTH BLADE, 10"	1
	EB6HD	HEAVY DUTY EARTH BLADE, 6"	1
	EB8HD	HEAVY DUTY EARTH BLADE, 8"	1
	EB10HD	HEAVY DUTY EARTH BLADE, 10"	1
29	EBOLT	BOLT 1/4-28 X 5/8 HH GR5	2
30	ENUT	NUT 1/4-28 BI-WAY LOCK	2
31	8958HD	FISHTAIL POINT SHARPENED	1
	8970	POINT, EARTH 2" & 3" AUGERS	1
32	1433	BOLT 3/8-16 X 1-1/2 HH	1
33	2104	NUT 3/8-16 HEX LOCK BI-WAY	1
-	EXT6	DEPTH EXTENSION 6"	1
	EXT12	DEPTH EXTENSION 12"	1
	EXT18	DEPTH EXTENSION 18"	1

* Includes blade, fishtail point, shock spring, shock top, & hardware.

** Includes mounting hardware.

E43 ENGINE PARTS

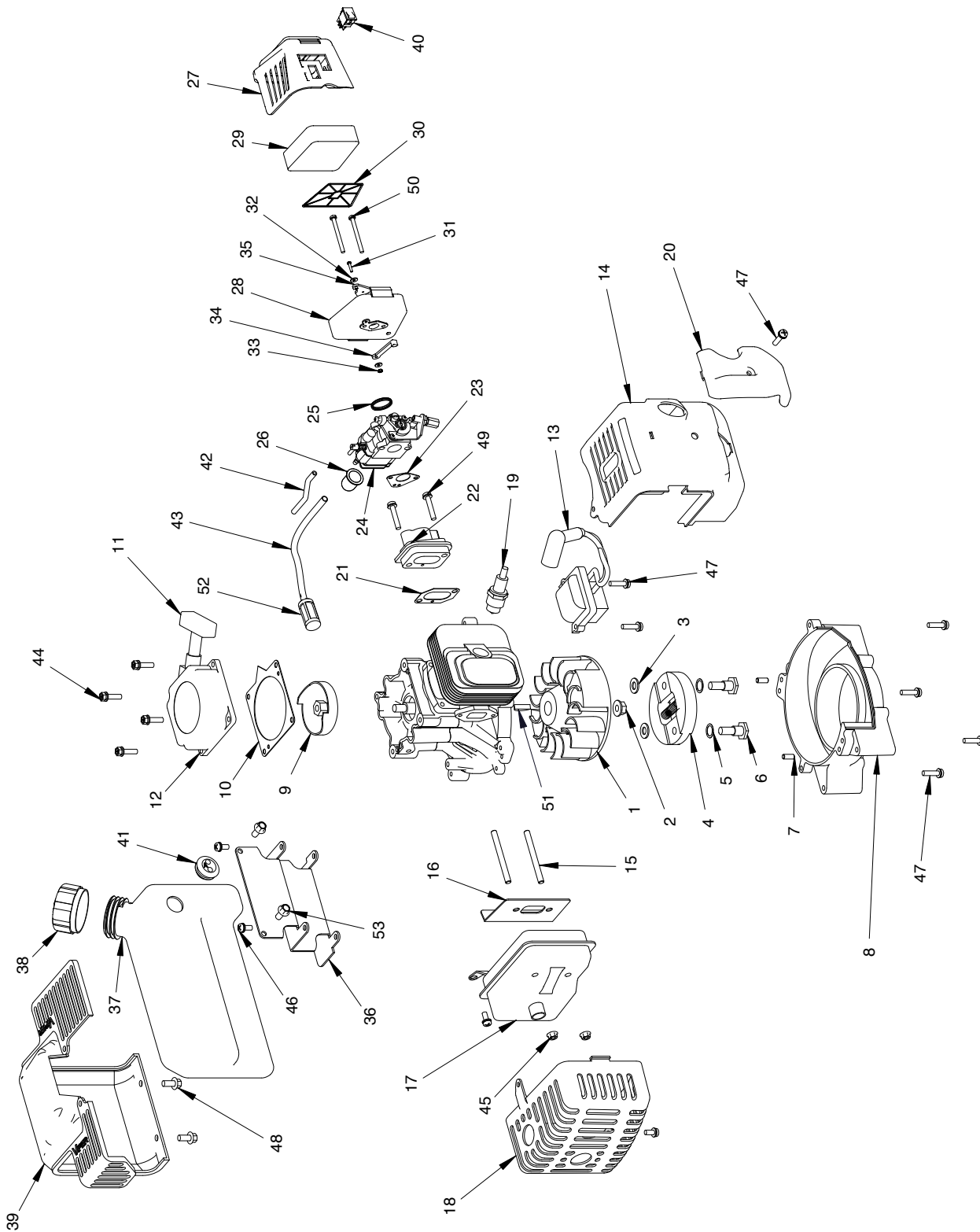

E43 ENGINE PARTS LIST

KEY NO.	PART NO.	DESCRIPTION	QTY.
1	300484	FLYWHEEL, MAGNETO	1
2	300337	NUT, FLANGE M8	1
3	300462	WASHER, ROTOR	2
4	300413	CLUTCH ROTOR ASSEMBLY W/SPRING	1
5	300449	WASHER, SPRING	2
6	300450	BOLT, SHOULDER	2
7	300467	PIN, LOCATING	2
8	3004110	MOUNT RING & SHROUD	1
9	300491	RECOIL CLUTCH	1
10	300429	PLATE, RECOIL	1
11	3004121	HANDLE, RECOIL (STANDARD)	1
12	300430	RECOIL ASSEMBLY WITH STANDARD HANDLE	1
13	300472	IGNITION COIL	1
13*	300472CE	IGNITION COIL CE	1
14	300482	SHROUD, ENGINE	1
15	300493	BOLT, STUD M6 X 62MM	2
16	300475	GASKET, MUFFLER	1
17	4813	MUFFLER	1
18	4812	COVER, MUFFLER	1
19	BM6A	SPARK PLUG	1
20	300483	COVER, ENGINE SHROUD	1
21	300476	GASKET, INTAKE	1
22	300478	WINDPIPE, INTAKE 43CC/51CC	1
23	300479	GASKET, CARBURETOR	1
24	300486	CARBURETOR	1
25	300481	O-RING, CARBURETOR	1
26	3004109	PRIMER BULB	1
27	3004158	COVER, AIR FILTER	1
28	3004150	AIR FILTER ASSEMBLY	1
29	3004156	FOAM, AIR FILTER	1
30	3004157	PLATE, REINFORCEMENT	1
31	3004150	AIR FILTER ASSEMBLY	1
32	3004150	AIR FILTER ASSEMBLY	2
33	3004150	AIR FILTER ASSEMBLY	1
34	3004150	AIR FILTER ASSEMBLY	1
35	3004150	AIR FILTER ASSEMBLY	1

KEY NO.	PART NO.	DESCRIPTION	QTY.
36	56105	BRACKET, GAS TANK	1
37	3004118	GAS TANK KIT (INCLUDES TANK. GROMMET, FUEL LINE, FUEL FILTER AND GAS CAP.)	1
38	300401	GAS CAP, MANUAL VENTING	1
39	300332	SHROUD, GAS TANK	1
40	1021	SWITCH, ROCKER	1
41	3004105	KIT FUEL LINE TWO HOLE GROMMET	1
42	3004105	KIT FUEL LINE TWO HOLE GROMMET	1
43	3004105	KIT FUEL LINE TWO HOLE GROMMET	1
44	300335	BOLT W/WASHER PHILLIPS HH	4
45	300492	NUT, FLANGE M6	2
46	300471	BOLT W/WASHER M5 X 12MM	4
47	300439	BOLT W/WASHER PH M5 X 18MM	7
48	300336	BOLT HH M6 X 10MM	2
49	300438	BOLT W/WASHER M5 X 25MM	2
50	300456	BOLT M5 X 50MM	2
51	300338	KEY, FLYWHEEL	1
52	3004103	FILTER, FUEL	1
53	300351	BOLT HH M6 X 8MM	2
-	3004114	KIT, CARBURETOR	1

* For E43CE Only.